

DEUTZ BFM 1013

For generator sets ■ 81 - 225 kW | 109 - 302 hp at 1500/1800 min⁻¹|rpm ■ EU Stage II / US EPA Tier 2

- Water-cooled 4 and 6-cylinder inline engines with turbocharging and charge air cooling.
- The robust engine design allows worldwide operation even with high sulphur fuels.
- Easy, inexpensive installation due to minimum weight and small installation space.
- Best cold starting performance even under extreme conditions.
- Low noise emissions due to acoustically optimized components with very smooth running and high durability.
- Also available with an electronic motor regulator (EMR) to allow easy integration into the electronic device control and monitoring system.
- A very good load response ensures an immediate power supply.

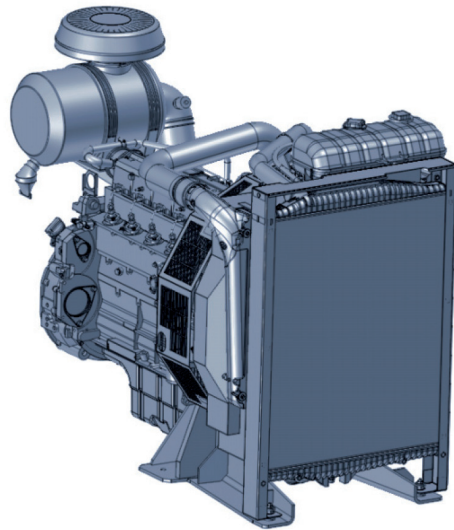

TECHNICAL DATA

Engine type		BF4M 1013 EC	BF4M 1013 FC	BF6M 1013 EC	BF6M 1013 FC
No. of cylinders		4	4	6	6
Bore/stroke	mm in	108/130 4.25/5.12	108/130 4.25/5.12	108/130 4.25/5.12	108/130 4.25/5.12
Displacement	l cu in	4.8 291	4.8 291	7.2 436	7.2 436
Weight (incl. cooler and fan)	kg lb	560 1235	560 1235	770 1698	770 1698
Governing standard ¹⁾		G2	G2	G2	G2

50 Hz / 1500 min⁻¹ | rpm

Power		BF4M 1013 EC	BF4M 1013 FC	BF6M 1013 EC	BF6M 1013 FC
Continuous Power COP ²⁾	kW hp	81.0/92.0 108.6/123.4	106.0 142.1	139.0 186.4	166.0 222.6
Prime Power PRP ³⁾	kW hp	85.0/97.0 114.0/130.1	117.0 156.9	146.0 195.8	183.0 245.4
Limited Time Power LTP ⁴⁾	kW hp	89.0/102.0 119.4/136.8	129.0 173.0	153.0 205.2	201.0 269.5
Fan power consumption	kW hp	5.9 7.9	5.0 6.7	7.2 9.7	7.2 9.7
Typical Generator Output COP ⁵⁾	kVA	85/97	116	152	183
Typical Generator Output PRP ⁵⁾	kVA	89/103	129	160	202
Typical Generator Output LTP ⁵⁾	kVA	94/108	143	168	223

60 Hz / 1800 min⁻¹ | rpm

Power		BF4M 1013 EC	BF4M 1013 FC	BF6M 1013 EC	BF6M 1013 FC
Continuous Power COP ²⁾	kW hp	86.0/100.0 115.3/134.1	112.0 150.2	148.0 198.5	186.0 249.4
Prime Power PRP ³⁾	kW hp	90.0/105.0 120.7/140.8	124.0 166.3	155.0 207.9	204.0 273.6
Limited Time Power LTP ⁴⁾	kW hp	95.0/110.0 127.4/147.5	136.0 182.4	163.0 218.6	224.9 301.6
Fan power consumption	kW hp	10.2 13.7	8.7 11.7	8.7 11.7	12.4 16.6
Typical Generator Output COP ⁵⁾	kWe	68/81	93	128	160
Typical Generator Output PRP ⁵⁾	kWe	72/85	104	135	176
Typical Generator Output LTP ⁵⁾	kWe	76/90	115	142	196

1) According to ISO 8528-5.

2) Continuous Power: No time limitation, plus 10% additional power for governing purpose only.

3) Prime Power: Average power output ≤ 80%, no time limitation, plus 5% additional power for governing purpose only.

4) Limited Time Running Power: For up to 500 h/year, thereof a maximum of 300 h/year continuous running.

5) In consideration of a generator efficiency level of 90 - 92 % and a power factor of 0.8.

50 Hz / 1500 min⁻¹ | rpm

Fuel Consumption PRP ¹⁾		BF4M 1013 EC	BF4M 1013 FC	BF6M 1013 EC	BF6M 1013 FC
Fuel consumption 25% load	g/kWh lb/hph	246/237 0.40/0.39	221 0.36	234 0.38	222 0.36
Fuel consumption 50% load	g/kWh lb/hph	215/214 0.35/0.35	204 0.34	213 0.35	210 0.35
Fuel consumption 75% load	g/kWh lb/hph	210/211 0.35/0.35	203 0.33	209 0.34	208 0.34
Fuel consumption 100% load	g/kWh lb/hph	209/212 0.34/0.35	210 0.35	209 0.34	212 0.35
Heat balance & cooling system		BF4M 1013 EC	BF4M 1013 FC	BF6M 1013 EC	BF6M 1013 FC
Heat dissipation (engine radiator) ²⁾	kW hp	47.8/52.5 64.1/70.4	62.7 84.1	68.4 91.7	96.1 128.9
Heat dissipation CAC ²⁾	kW hp	9.9/13.1 13.3/17.6	23.7 31.8	24.0 32.2	42.0 56.3
Heat dissipation (convection)	kW hp	9.0/10.0 12.0/13.0	13.0 17.0	15.5 20.8	20.0 26.8
Cooling air flow	m ³ /h cfm	6100 3590	9000 5297	10800 6357	11520 6780
Inlet & exhaust data		BF4M 1013 EC	BF4M 1013 FC	BF6M 1013 EC	BF6M 1013 FC
max. intake depression	mbar psi	25 0.36	25 0.36	25 0.36	25 0.36
Combustion air volume	m ³ /h cfm	329/365 194/215	482 284	639 376	746 439
max. exhaust gas temperature	°C °F	540/560 1004/1040	530 986	535 995	530 986
Exhaust gas flow	m ³ /h cfm	951/1102 560/649	1389 818	1799 1059	2112 1243

60 Hz / 1800 min⁻¹ | rpm

Fuel Consumption PRP ¹⁾		BF4M 1013 EC	BF4M 1013 FC	BF6M 1013 EC	BF6M 1013 FC
Fuel consumption 25% load	g/kWh lb/hph	270/251 0.44/0.41	235 0.39	253 0.42	231 0.38
Fuel consumption 50% load	g/kWh lb/hph	228/219 0.37/0.36	212 0.35	220 0.36	215 0.35
Fuel consumption 75% load	g/kWh lb/hph	217/213 0.36/0.35	211 0.35	214 0.35	214 0.35
Fuel consumption 100% load	g/kWh lb/hph	215/212 0.35/0.35	219 0.36	214 0.35	221 0.36
Heat balance & cooling system		BF4M 1013 EC	BF4M 1013 FC	BF6M 1013 EC	BF6M 1013 FC
Heat dissipation (engine radiator) ²⁾	kW hp	51.8/53.3 69.5/71.5	68.1 91.3	73.5 98.6	109.8 147.2
Heat dissipation CAC ²⁾	kW hp	17.3/21.0 23.2/28.2	30.7 41.2	33.7 45.2	50.9 68.3
Heat dissipation (convection)	kW hp	9.5/11.0 12.7/14.8	13.5 18.1	16.0 21.5	22.5 30.2
Cooling air flow	m ³ /h cfm	7600 4473	11520 6780	11500 6769	14760 8687
Inlet & exhaust data		BF4M 1013 EC	BF4M 1013 FC	BF6M 1013 EC	BF6M 1013 FC
max. intake depression	mbar psi	25 0.36	25 0.36	25 0.36	25 0.36
Combustion air volume	m ³ /h cfm	425/466 250/274	576 339	801 472	946 557
max. exhaust gas temperature	°C °F	490/520 914/968	530 986	480 896	530 986
Exhaust gas flow	m ³ /h cfm	1160/1316 683/775	1653 973	2097 1234	2666 1569

1) Refers to diesel with a density of 0.835 kg/dm³ at 15°C | 6.96 lb/US gallon at 60°F.

2) The heat quantities are valid for the dimensioning of the cooling system.

DIMENSIONS

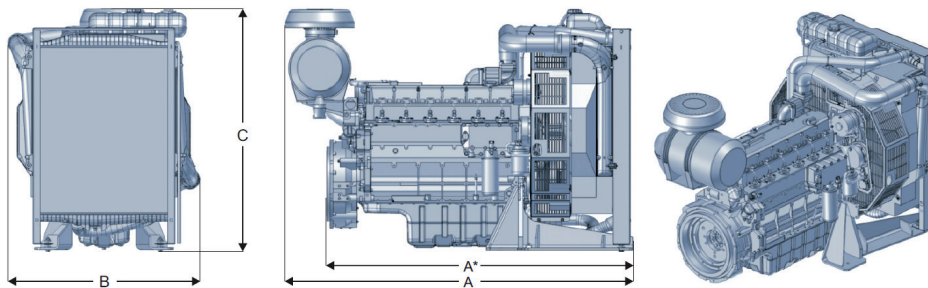

Engine type		A	A*	B	C
BF4M 1013 EC/FC	mm in	1479 58	1250 49	728 29	1151 45
BF6M 1013 EC	mm in	1870 74	1641 65	866 34	1239 49
BF6M 1013 FC	mm in	1923 76	1694 67	1003 39	1586 62

* Note: The engine dimensions and weights vary depending on the scope of delivery.

The data on this data sheet are for information purposes only and are not binding values. For more information please contact your responsible sales partner.

DEUTZ AG
 Ottostraße 1
 51149 Cologne, Germany
 Phone: +49 (0) 221 822-0
 Telefax: +49 (0) 221 822-3525
 E-Mail: info@deutz.com
 www.facebook.com/deutzofficial
 www.deutz.com

The engine company. 